

Milan Stibilj

ÉPERVIER DE LA FAIBLESSE

Partitur

Bärenreiter Kassel · Basel · Paris · London · New York

Leihmaterial - Unverkäuflich















MILAN STIBILJ

ÉPÉRVIER DE TA FAIBLESSE, DOMINE!

for speaker and percussion ensemble / 5 players /

poem by Henri Michaux

SYMBOLS

-  soft felt-headed drumstick
 -  hard felt-headed drumstick
 -  leather-headed drumstick
 -  hard rubber-headed drumstick
 -  wooden drumstick
 -  xylophone mallet
 -  xyl. mallet with plaster
 -  wooden hammer
 -  triangle rod
 -  brushes
 -  strike with hands
 -  strike at edge
 -  strike in the middle
 -  strike the edge
 -  foot pedal / bass drum /
- } of the instr.



allow the sound to fade away



mute the sound



rhythmical improvisation

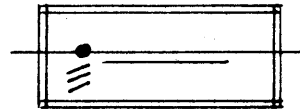

duration of a sound in improv.

accelerando /ritardando/ within the
rhythmical worth



written



performed

POSITION OF INSTRUMENTS IN THE SCORE

I

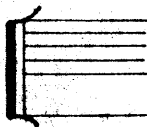

4 timpani /timp/
wood chimes /w. ch/
speaker

5 bongos / relative pitch /

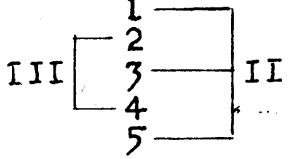

largeness of cymbals

1	2	3	4	5
○	○	○	○	○
II	III		V	IV

II



3 tom tom /tom/
3 bongos /bgs/
tenor drum /tamb.rull/
cymbal /cym/
chinese gong /gng/



xylophone /xyl/

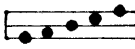

5 wood blocks /w.bl./

2 maracas /mrc/

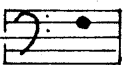

III

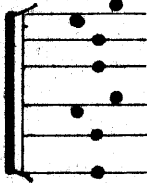

2 bgs
conga /small/ /cng/
snare drum /tamb.mil/
2 cym
gng with hump
glass chimes /glass/

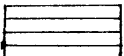

xyl



6 tubular bells /bell/

IV

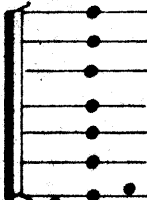

cng /large/
tambourine /tambrn/
bass drum /bas/ with foot pedal
cym
gng
tam tam /large/ /tam/
3 cow bells /cow/ (2 mrc)

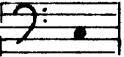

V

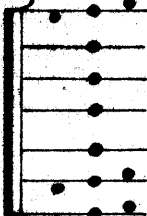

3 tom
cym
gng
tam /medium/
guiro /gro/
3 bottles /bottle/
3 triangles /trg/

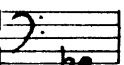
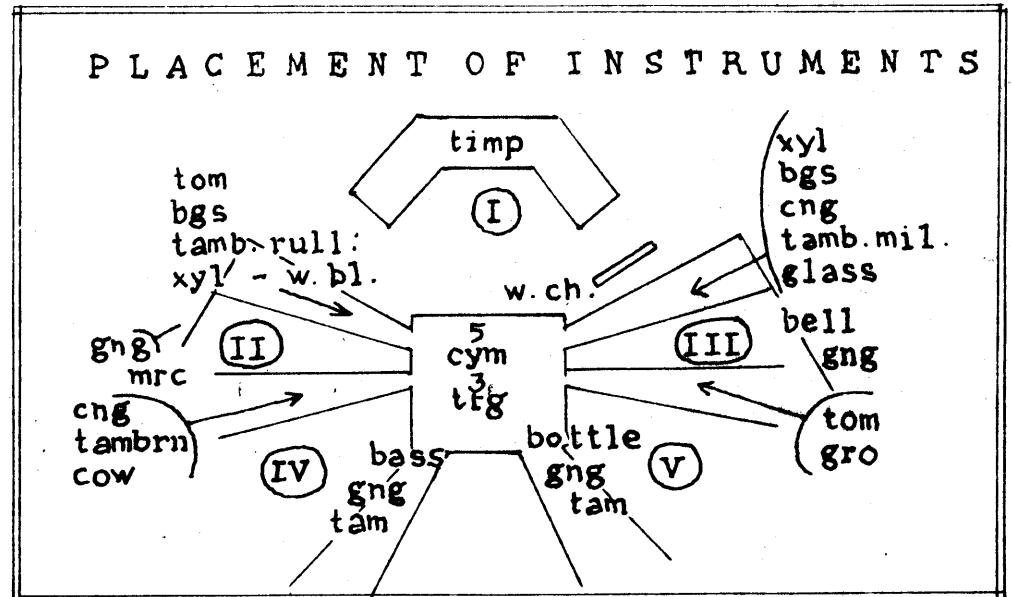
MILAN STIBILJ: ÉPERVIER DE TA FAIBLESSE, DOMINE (RITMIČNA STRUKTURA IN SEŠTAVINE 17 VARIACI)

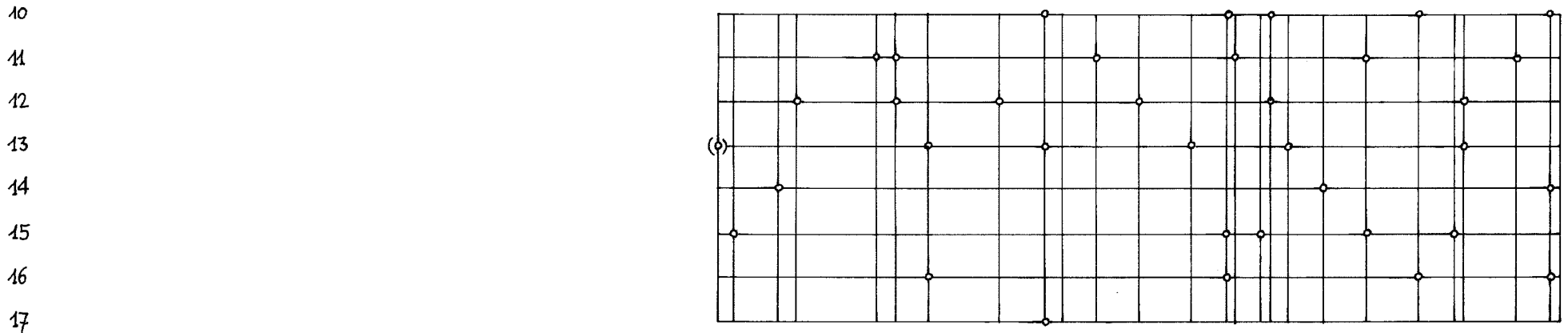
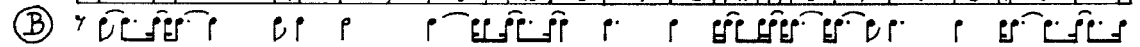
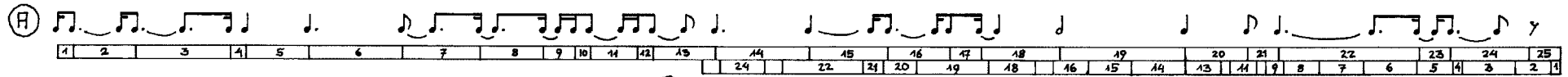
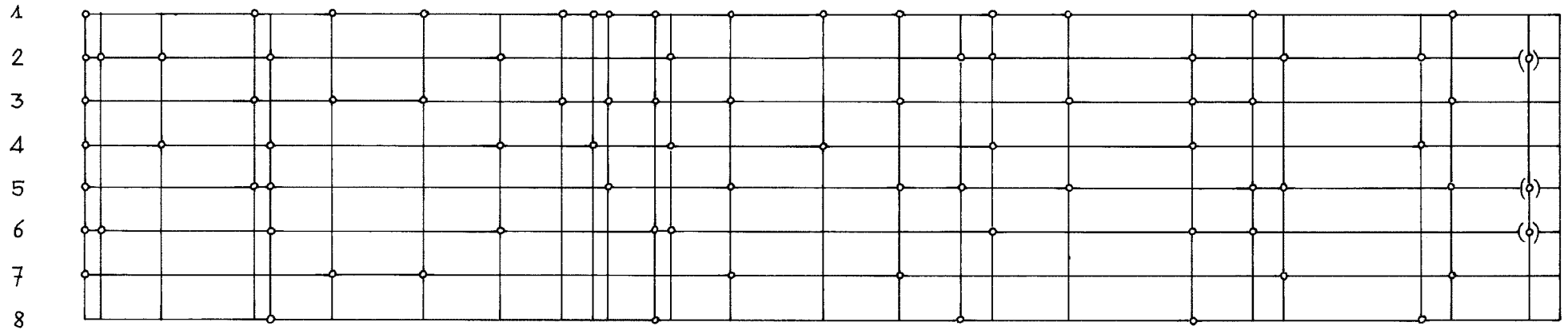
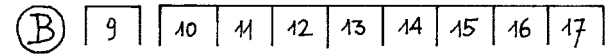
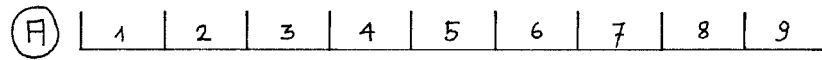

♩ = 52

timp

1

I

pp P ppp P pp p pp mp pp

3
4

II

III

IV

V

Main musical staff with dynamics and articulation markings: *pp*, *ppp*, *mf*, *mf*. Includes a triplet of eighth notes and a circled note with an arrow.

Percussion staves for **tom** and **bgs**. The **tom** staff features a triplet of eighth notes marked *pp* and a circled note. The **bgs** staff includes a circled note marked *mp* and another circled note marked *mf*.

Percussion staves for **cng**, **bass**, **tambrn**, and **cym**. The **cng** staff has a circled note marked *pp*. The **bass** staff has a circled note marked *pp*. The **tambrn** staff has a circled note marked *mf*. The **cym** staff has circled notes marked *p*, *mp*, and *p*.

3

Main melodic line with various musical notations including triplets, accents, and dynamics. The line starts with a circled note and an arrow pointing right. It includes a triplet of eighth notes, a circled note with an arrow, and a circled note with a right-pointing arrow. Dynamics include *mf*, *p*, *f*, *mf*, *p mp*, and *mf*. There are also some handwritten notes like "piss" and "piss".

Musical staff for 'bgs' and 'tom'. It features five-finger patterns (marked with '5') and dynamics *p*, *mf*, and *p*. The 'tom' part includes a circled note and a triplet of eighth notes.

Musical staff for 'bgs' and 'cng'. It features five-finger patterns (marked with '5') and dynamics *mp*, *mf*, and *p*. The 'cng' part includes a circled note and a triplet of eighth notes.

Musical staff for 'bass'. It contains notes and dynamics *mf* and *mp*.

Musical staff for 'tom'. It includes notes, dynamics *pp*, *f*, and *f*, and a large chordal structure with many notes.

Musical staff with notes, dynamics (mp, f, pp, p), and articulation marks.

Musical staff for 'tom' and 'bgs' with dynamics (p, mf, f).

Musical staff for 'cym' with dynamics (f, ff).

Musical staff for 'bgs' with dynamics (mf).

Musical staff for 'tamb.n.' and 'cym' with dynamics (f, p).

Musical staff for 'bass' and 'tamb.n.' with dynamics (p).

Musical staff for 'cym' and 'gng' with dynamics (f, mf, p).

Musical staff for 'tom' with dynamics (mf).

Musical staff for 'cym' and 'gng' with dynamics (p, f).

♩ = 60

Main musical staff with notes, rests, and dynamic markings. Includes a fermata over a measure and a gliss. marking.

mf

5

Je suis l'oiseau.

Tu es l'

pp

Percussion staves for cym, tamb.mil, cng, and cym gng tam. Includes dynamic markings like f and mf.

Percussion staves for bgs cng, tambrn bas, and tom. Includes dynamic markings like ff and p.

oiseau. Je suis la flèche empennée des plumes de l'oiseau Je vole. Tu

Musical staff with notes and dynamics markings: *mf*, *pp*, *p*.

voles. Je vogue. Tu vagues. Nous voguons entre les mâchoires du ciel et de

Musical staff for guitar/bass with dynamics and articulation: *p*, *pp*, *mf*, *f*, *bgs*, *tom*, *p*.

Musical staff for guitar/bass with triplets and dynamics: *bgs*, *f*, *c*, *cng*, *f*.

Musical staff for bass and tom with dynamics and articulation: *bass cym*, *f*, *tom*, *p*, *mf*, *p*.

A musical staff with notes and dynamics. The dynamics are p, p, f, and pp. There are also some markings like 'giss' and 'Q' above the notes.

la Terre

Je romps

Je plie Je coule Je m'appuie

A percussion score with multiple staves. The instruments and their parts are:

- bgs** (bongos): Two staves with notes and rests.
- cym** (cymbal): Two staves with notes and rests.
- glass**: One staff with notes and rests.
- tambrn** (tambourine): One staff with notes and rests.
- bass**: One staff with notes and rests.
- cym gng** (cymbal/gong): One staff with notes and rests.

 Dynamics include mf, pp, p, and f. There are also some markings like 'Q' and 'p' above notes.

Musical staff with notes and dynamics: *mf*, *mf*, *p*, *mf*

sur les coups que l'on me porte

Je gratte J'obstrue

J'obnubile

Je fais rétrograder la marche des vivants

Percussion and guitar accompaniment staves with various notations like *bgs*, *cym.*, *tom*, *gng*, *tambrn*, *bass*, *tam* and dynamics like *mf*, *p*, *mp*, *f*.

Musical staff with vocal line. Dynamics include *p*, *gliss*, *mf*, *p*, *f*, and *ff*. There are circled numbers 3 and 9 above the staff.

Et toi, qui en misère
as abondance

Et toi,

Accompaniment staves for percussion and instruments. Includes staves for *tom*, *bgs*, *cng*, *cym*, *glass*, *tambrn*, *bass*, *guiro*, and *tom cym*. Dynamics include *mf*, *p*, *f*, *mp*, and *pp*. There are circled numbers 3 and 9 above the *tom cym* staff.

♩ = 72

Musical staff with notes and glissando markings. Dynamics include *ff* and *gliss*.

Par ta soif, du moins, tu es soleil,

Épervier de ta

Musical staff for gong and cymbal. Includes notes, rests, and dynamics like *mf*, *ff*, and *cym*.

Musical staff for cymbal and tambourine. Includes notes, rests, and dynamics like *mf* and *ff*.

Musical staff for bass and tambo. Includes notes, rests, and dynamics like *mf* and *tambo*.

Musical staff for tom, cym, gng, and tam. Includes notes, rests, and dynamics like *mf*.



faiblesse,

domine!

mf Ton

A percussion score consisting of four staves. The instruments and their parts are:

- Staff 1:** Labeled 'gng' (gong). It features a quarter note (Q) and a fermata. Dynamics include fortissimo (ff) and piano (p).
- Staff 2:** Labeled 'cym' (cymbal) and 'bgs' (bells). It includes a fermata and a section with a 'glass' (gong) and 'cng tambrn' (cymbal/tam-tam) section. Dynamics include piano (p) and fortissimo (f).
- Staff 3:** Labeled 'cym' and 'gng'. It includes a fermata and a section with a 'cym' and 'gng' section. Dynamics include piano (p) and fortissimo (f).
- Staff 4:** Labeled 'gng' and 'tam'. It includes a fermata and a section with a 'cym' section. Dynamics include piano (p) and fortissimo (f).

The score uses various musical notations such as beams, slurs, and dynamic hairpins to indicate performance instructions.

égoût traverse la Royale Demeure

Six mille lames de mots tu as en ta bouche

Handwritten musical score for the piece "égoût traverse la Royale Demeure". The score is written on four staves:

- Staff 1 (Tambourin):** Labeled "tamb.rull". It begins with a rest, followed by a quarter note, and then a series of eighth notes with a dynamic marking of *mf*.
- Staff 2 (Congas):** Labeled "cng". It features a sequence of eighth notes with a dynamic marking of *mp*, followed by a crescendo leading to a fortissimo (*f*) section.
- Staff 3 (Cymbal and Bass):** Labeled "cym" and "bass". It contains a series of notes with dynamic markings of *f* and *p*.
- Staff 4 (Cymbal):** Labeled "cym". It features a series of notes with a dynamic marking of *mf*.

Handwritten musical score for the piece "Six mille lames de mots tu as en ta bouche". It consists of a single staff labeled "tamb.rull". The notation shows a series of notes with a dynamic marking of *mf* and a crescendo leading to a fortissimo (*f*) section.

Handwritten musical score for the piece "Six mille lames de mots tu as en ta bouche". It consists of a single staff with notes and rests, continuing the piece.

Faible, dis-tu.

Qui est faible, traversant les quatre

The image shows a handwritten musical score for three staves. The first staff has a dynamic marking of *p* and a *mf* marking with a crescendo hairpin. It contains several chords and a triplet of eighth notes marked *f*. The second staff has a dynamic marking of *p* and contains a triplet of eighth notes marked *f* and a *fpp* marking. The third staff has a dynamic marking of *p* and contains a triplet of eighth notes marked *f*. The score includes various annotations such as *tamb.mil*, *bgs*, *cn g*, and *tambrn*, along with dynamic markings like *p*, *mf*, *f*, and *fpp*. There are also some numerical annotations like '7' and '3'.

♩ = 84

mondes?

The musical score is written for a percussion ensemble. It consists of several staves with rhythmic notation and dynamic markings. The instruments and their parts are as follows:

- bgs (Bongos):** Located at the top left, it features a rhythmic pattern of eighth notes and quarter notes, starting with a square symbol. Dynamic markings include *f*.
- cym (Cymbal):** Multiple staves show cymbal patterns with various dynamics such as *f*, *mp*, and *p*. Some notes are marked with a circled 'Q'.
- gng (Gong):** A staff in the middle left shows gong patterns with dynamics like *p* and *mf*.
- tam (Tambourine):** A staff in the middle right shows tambourine patterns with dynamics like *p* and *mf*.
- xylophone:** Two staves in the middle right show xylophone patterns with dynamics like *p* and *mf*.
- bass:** A staff at the bottom left shows bass drum patterns with dynamics like *f* and *mf*.
- cng (Conga):** A staff at the top left shows conga patterns with dynamics like *f* and *mf*.
- tambrn (Tambourine):** A staff at the bottom left shows tambourine patterns with dynamics like *f* and *mf*.

The score includes various rhythmic notations such as eighth notes, quarter notes, and rests, along with dynamic markings like *f* (forte), *mp* (mezzo-piano), and *p* (piano). Some notes are marked with a circled 'Q', possibly indicating a specific performance technique or accent.

♩ = 72

Handwritten musical score for percussion instruments. The score is organized into six staves, with some staves grouped by brackets. The instruments and their parts are as follows:

- Staff 1 (Tympani):** Labeled "timp". Contains a few notes, including a half note with a dynamic marking of *mf*.
- Staff 2 (Xylophone):** Labeled "xyl". Contains a melodic line with various dynamics including *mf*, *f*, and *mf*.
- Staff 3 (Xylophone):** Labeled "xyl". Contains a melodic line with dynamics *f* and *mf*.
- Staff 4 (Gong):** Labeled "gng". Contains notes with dynamics *mf* and *p*.
- Staff 5 (Cymbal):** Labeled "cym". Contains notes with dynamics *p* and *mf*.
- Staff 6 (Tambourine):** Labeled "tam". Contains notes with dynamics *mf* and *p*.

Additional markings include a 3/4 time signature in the middle of the score, various articulation marks (accents, slurs), and dynamic markings such as *pp*, *mp*, *f*, and *pp*.

This page contains a handwritten musical score for a percussion ensemble, consisting of seven staves. The notation includes various rhythmic patterns, dynamic markings, and performance instructions. The first staff begins with a *gliss* marking. The second and third staves feature *cym* (cymbal) markings and include dynamic markings such as *mf*, *f*, and *ff*. The fourth staff includes *gng* (gong) markings and dynamics like *mf* and *f*. The fifth staff contains *tam* (tam-tam) markings and dynamics including *mf*, *f*, and *ff*. The sixth staff has *cym* markings and dynamics such as *mp*, *p*, and *pp*. The seventh staff includes *tam* markings and dynamics like *mf*, *p*, and *pp*. The score is written in a fluid, handwritten style with various slurs and accents.

Musical staff for wood chimes. It features a treble clef, a key signature of one sharp (F#), and a 7/8 time signature. The notation includes quarter notes and eighth notes with dynamic markings *qiss* and *miss*. The word "wood chimes" is written below the staff, followed by a fortissimo (*ff*) dynamic marking and an upward-pointing arrow.

Regarde:

fff

Musical staff with complex notation, including beamed eighth and sixteenth notes, and various accidentals. It includes a fortissimo (*fff*) dynamic marking.

Musical staff with complex notation, including beamed eighth and sixteenth notes, and various accidentals. It includes a fortissimo (*fff*) dynamic marking.

Musical staff for cym (cymbal). It features a treble clef and a 7/8 time signature. The notation includes quarter notes and eighth notes with dynamic markings *gng*, *mf*, and *fff*. The word "cym" is written above the staff.

Musical staff for tam (tam-tam). It features a treble clef and a 7/8 time signature. The notation includes quarter notes and eighth notes with dynamic markings *gng* and *tam*. The word "tam" is written above the staff.

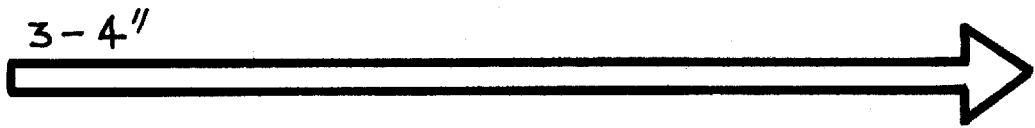

♩ = 72

Handwritten musical score for percussion instruments and voice. The score is divided into two systems.

System 1 (Left):

- w.ch.:** A staff with a circled note and an arrow pointing to it.
- wood blocks:** A staff with a rhythmic pattern of notes, starting with a *p* dynamic and ending with a *fff* dynamic. Includes a circled note.
- bell:** A staff with notes and a *fff* dynamic.
- gng:** A staff with notes and a *fff* dynamic.
- bass:** A staff with notes and a *fff* dynamic.
- cym:** A staff with notes and a *fff* dynamic.
- tam:** A staff with notes and a *fff* dynamic.

System 2 (Right):

- timp:** A staff with notes and a *mf* dynamic.
- cow:** A staff with notes and a *fff* dynamic.
- bottle trg:** A staff with notes and a *fff* dynamic.

Vocal Line: A staff with the lyrics "Je fais tourner la" and a *fff* dynamic. Includes a *gliss* marking.

Other markings: A 3/4 time signature is present on the left. Various dynamics (*p*, *mf*, *fff*) and articulation marks (accents) are used throughout. Several notes and phrases are enclosed in boxes.

timp
w.ch.

Musical notation for timpani (timp) and w.ch. parts, showing notes and rests on a five-line staff.

femme Je lynche le vieillard l'enivre la racine Je galope

tamb.rull
cym
pp

tamb.mil
cym
p

cym
bass

cym
trg

cng
tambrn
mf

tam
mf

Detailed musical score for percussion instruments, including tamb.rull, cym, tamb.mil, bass, cng, tambrn, and tam. The score includes various musical notations such as notes, rests, and dynamic markings (pp, p, mf, f).

A musical staff with notes and glissando markings. The notes are on a treble clef staff. There are several glissando markings (gliss) and dynamic markings (p, ff). The staff is divided into two sections by a vertical line.

dans le troupeau de girafes

Je suis le guerrier parachuté

Musical staff for a woodwind instrument (w. bl.). It features a melodic line with notes and a dynamic marking of p. The staff is divided into two sections by a vertical line.

gng

Musical staff for a gong (gng) with a dynamic marking of mf. It shows a single note with a gong symbol above it. The staff is divided into two sections by a vertical line.

Musical staff for a cymbal (cym) with a dynamic marking of f. It shows a note with a cymbal symbol above it. The staff is divided into two sections by a vertical line.

bells

Musical staff for bells (bells) with a dynamic marking of f. It shows notes with bell symbols above them. The staff is divided into two sections by a vertical line.

Musical staff for maracas (maracas) with a dynamic marking of pp. It shows notes with maracas symbols above them. The staff is divided into two sections by a vertical line.

Musical staff for bass gong (bass gng) with a dynamic marking of mf. It shows notes with gong symbols above them. The staff is divided into two sections by a vertical line.

Musical staff for a gong (gro) with dynamic markings of mf and ff. It shows notes with gong symbols above them. The staff is divided into two sections by a vertical line.

Musical staff for cymbal (cym) and tam-tam (tam) with a dynamic marking of mf. It shows notes with cymbal and tam-tam symbols above them. The staff is divided into two sections by a vertical line.

Je suis l'oreille quand il y a du bruit Je trompe, je traverse

cym

gng

tamb.mil

mrc

bass

tambrn

cym

tam

tom

mp

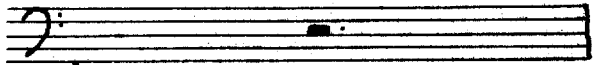

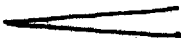
2 7 Je n'ai pas de
p 

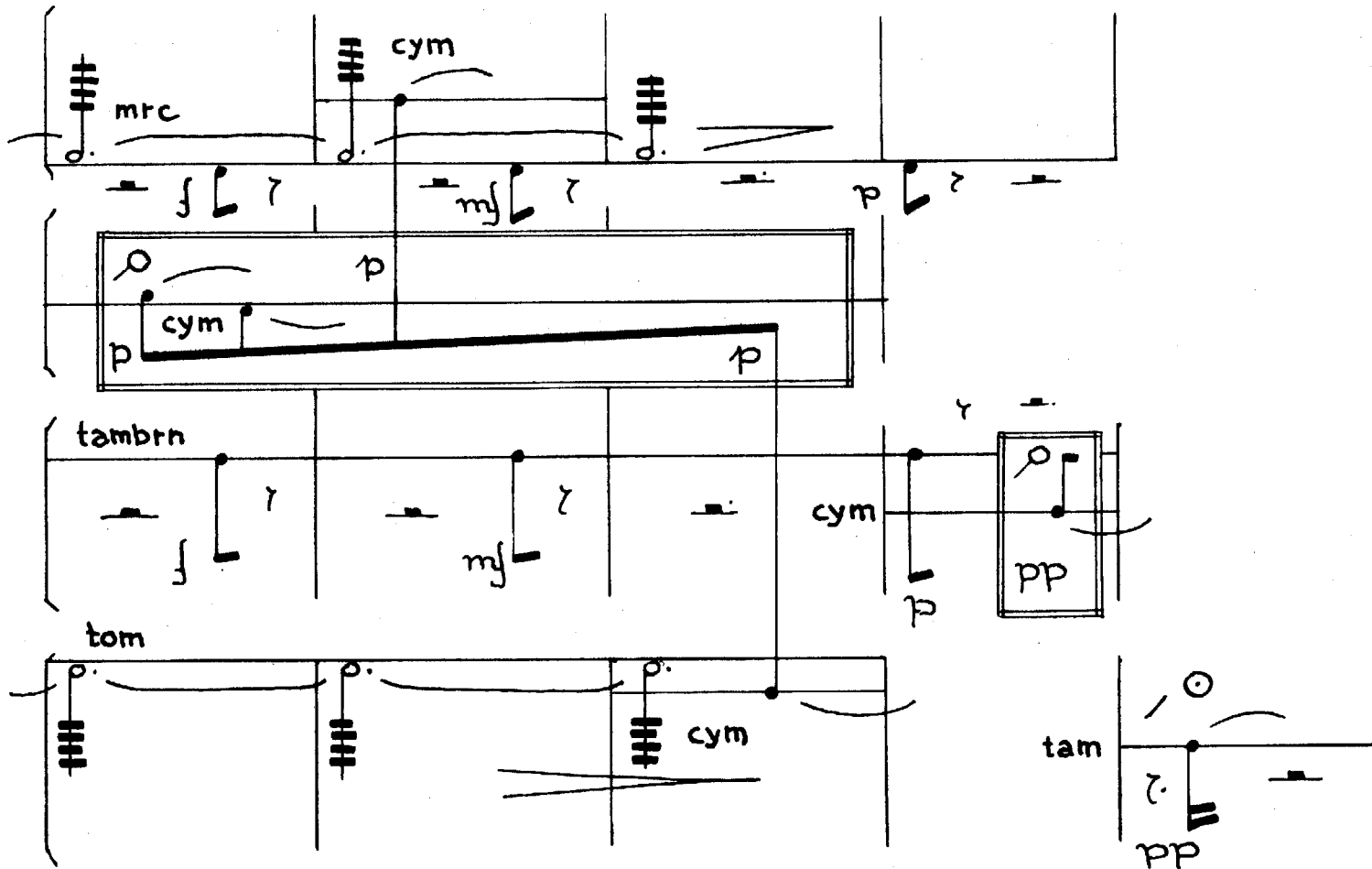

mrc

cym

tambrn

tom

cym

tam

pp

pp

The percussion score consists of five staves. The first staff, labeled 'mrc', shows a sequence of notes with dynamic markings *f*, *mf*, and *p*. The second staff, labeled 'cym', contains a large box with notes and dynamics *p* and *mf*. The third staff, labeled 'tambrn', has notes with dynamics *f*, *mf*, and *p*, and a box labeled 'pp'. The fourth staff, labeled 'tom', has notes with dynamics *f* and *mf*. The fifth staff, labeled 'tam', has notes with dynamics *f* and *pp*. Vertical lines connect notes across staves, indicating simultaneous sounds.

Handwritten musical score for guitar, drums, and bass. The guitar part features a melodic line with a '5' above a group of notes and a 'nom' box below. The drum part includes 'tamb.rull' and 'tambrn' with various dynamics like 'f' and 'fff'. The bass part includes 'bass', 'cym', 'tam', and 'gng' with dynamics like 'f' and 'mp'. A 'w. ch.' label is present between the guitar and drum parts.

Handwritten musical score for drums and tom. A box at the top contains the text 'Mon nom est de gaspiller les noms'. The drum part includes 'tom' and 'cym' with dynamics like 'p' and 'mp'. The tom part includes 'tom' with dynamics like 'p' and 'pp'.

timp *pp*

mf

bgs *p* *fp*

cym *p* *mf*

tambrn *p* *fp*

mrc *p* *fp*

trg *p*

bgs cng *p*

cng *f* *p*

bass *mf*

cng *mf*

cym *mf*

Q *mf*

Musical notation for a wind instrument, featuring glissando markings and a large rectangular graphic element.

Je suis le vent dans le vent

Musical notation for percussion instruments: tamb.rull, tamb.mil, bass, and gro, with dynamic markings and performance instructions.



Je suis celui qui enfanta les dieux

Dans mon bassin

mp

tom

mf

tom

ils ont été créés De mon bassin ils ont été chassés } Je ruine

tom *pp*

gng

p

f

cym

mf

p

tambrn

bass

mf

f

gng tam

tom

p

p

f

Je démets Je disloque

M'écoutant, le fils arrache les

The score is divided into three sections, each with five staves. The first section is marked *mf* and features a cymbal (cym) triplet in the second staff and a triangle (trg) in the fifth. The second section is marked *mf* and includes cowbells (cow) and a bottle in the fourth and fifth staves. The third section is marked *mp* and includes a w. bl. (wood block) in the top staff, a tambourine (tambn) and cymbal (cym) in the second, and a gong (gro) and triangle (trg) in the fifth. Dynamics range from *p* to *f*. The notation includes various rhythmic symbols such as beams, accents, and slurs.

testicules du Père

Je dégrade Je renverse Je renverse

mp >> p >>

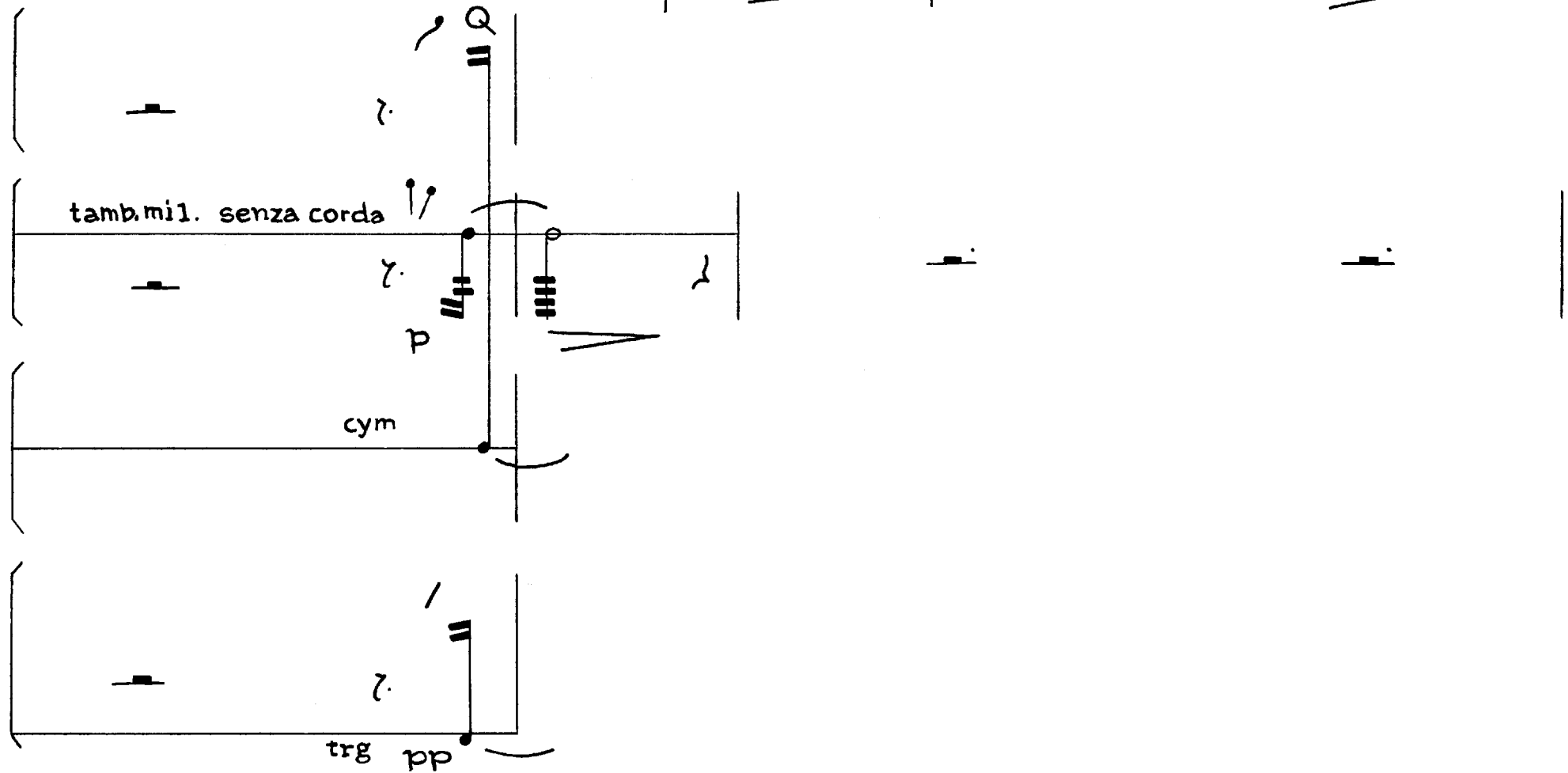

La tête dans ses tarots mes chiens dévorent la cartomancienne

Je renverse

Je ren...

The score is written on five staves. The first staff features a large box containing a graphic of a cymbal with a wedge-shaped shadow underneath, labeled 'cym' and 'p'. Above this staff is a box with the text 'La tête dans ses tarots mes chiens dévorent la cartomancienne' and a dynamic marking 'p'. The second staff is labeled 'glass' and contains a musical notation with a 'p' dynamic. The third staff is labeled 'cym' and contains a musical notation with a 'p' dynamic. The fourth staff is labeled 'trg' and contains a musical notation with a 'p' dynamic. The fifth staff is labeled 'bottle' and contains a musical notation with a 'p' dynamic. To the right of the score, there are two boxes: 'Je renverse' and 'Je ren...'. Above the 'Je renverse' box is a dynamic marking 'ppp' and a wedge-shaped symbol. Above the 'Je ren...' box is a wedge-shaped symbol. At the top of the page, there is a dynamic marking 'pp' and a wedge-shaped symbol.

HENRI MICHAUX

POEZIJA

BIBLIOTEKA ORION

Urednici

PETAR ŠEGEDIN
OTO ŠOLC
GRIGOR VITEZ

Preveo i izbor izveo

ZVONIMIR MRKONJIĆ



IZDAVAČKO KNJIŽARSKO PODUZEĆE

m l a d o s t

ZAGREB 1963

ÉPERVIER DE TA FAIBLESSE, DOMINE!

L' être qui inspire m' a dit:
Je suis celui qui tremble.
Je suis celui qui rompt,
Qui glisse, qui rampe.
Je suis celui qui rend.
L' être qui transporte m' a dit:
Je suis celui qui cesse,
Celui qui ôte, celui qui lâche.
Eh bien! et toi?
Et toi pareil, pourquoi te méconnaissais-tu?
Je m' assieds en juge,
Je m' accroupis en vache,
Je pénètre en père,
J' enfante en mère.
Et toi, qu' attends-tu?

Ton égoût traverse la Royale Demeure.
Six mille lames de mots tu as en ta bouche.
Faible, dis-tu.
Qui est faible, traversant les quatre mondes?

Je suis l' oiseau. Tu es l' oiseau.
Je suis la flèche empennée des plumes de l' oiseau
Je vole. Tu voles.
Je vogue. Tu vogues.
Nous vogueons entre les mâchoires du ciel et de
la Terre

JASTREBE TVOJE SLABOSTI, VLADAJ

Biće koje nadahnjuje reče mi:
Ja sam onaj koji drhti.
Ja sam onaj koji razbija,
Koji kliže, koji se penje.
Ja sam onaj koji vraća.
Biće što zanosi reče mi:
Ja sam onaj koji prestaje,
Koji otima, koji ispušta.
Pa dobro, a tko si ti?
Ti, meni sličan, zašto sebe ne znaš?
Sjedam kao sudac,
Čučnem kao krava,
Prodirem kao otac,
Rađam kao majka.
A ti, što čekaš?

Odvod tvoje nečisti prolazi kroz kraljevski stan.
Šest tisuća oštrica riječi imaš u ustima.
Slab si, kažeš.
Tko je slab koji četiri svijeta prelazi?

Ja sam ptica. Ti si ptica.
Ja sam strijela okićena ptičjim perjem.
Ja letim. Ti letiš.
Ja plovim. Ti ploviš.
Plovimo između čeljusti neba i Zemlje.

Je romps
Je plie
Je coule
Je m'appuie sur les coups que l'on me porte
Je gratte
j'obstrue
J'obnubile
Je fais rétrograder la marche des vivants
Et toi, qui en misère as abondance
Et toi,
Par ta soif, du moins, tu es soleil,
Épervier de ta faiblesse, domine!

Regarde:

Je fais tourner la femme
Je lynche le vieillard
J'enivre la racine
Je galope dans le troupeau de girafes
Je suis le guerrier parachuté
Je suis l'oreille quand il y a du bruit
Je trompe, je traverse
Je n'ai pas de nom
Mon nom est de gaspiller les noms

Je suis le vent dans le vent

Je suis celui qui enfanta les dieux
Dans mon bassin ils ont été créés
De mon bassin ils ont été chassés

Je ruine
Je démet
Je disloque
M'écoutant, le fils arrache les testicules du Père

Razbijam
Savijam
Tonem
Naslanjam se o udarce što mi zadaju
Grebem
Zakrčujem
Mračim
Unatrag pokrećem hod živih.
A ti, kome je bijeda obilje
A ti,
Svojom glađu bar si sunce,
Jastrebe tvoje slabosti, vladaj!

Gledaj:

Tjeram ženu da se okreće
Linčujem starca
Opijam korijen
Galopiram u čoporu žirafa
Ratnik sam spušten padobranom
Ja sam uho kad ima šumova
Ja varam, prelazim
Nemam imena
Moje ime rasipništvo je imenâ

Ja sam vjetar usred vjetra

Onaj sam koji je rodio bogove
U mojoj zdjeli oni su stvoreni
Iz moje su zdjele protjerani

Razaram
Svrgavam
Raščinjam
Slušajući mene sin kida mošnje ocu

Je dégrade

Je renverse

Je renverse

La tête dans ses tarots mes chiens dévorent la cartomancienne.

Kvarim

Obaram

Obaram

Moji psi proždiru gataru što je uronila glavu
u svoje karte.

 **prospective 21^e siècle**

Gravure Universelle 836.991 DSY



stibilij
ēpervier de ta faiblesse